



PRODUCT SPECIFICATION

Product Name

English Name : Cheese Sticks
Chinese Name : 芝士条

Product Brand

Brand : Nil

Product Descriptions

Colour : Light Orange
Shape : Rod Shape
General : Breaded Cheese-Based Product

Ingredients / Compositions

Cheese [Part Skim Mozzarella Cheese (Pasteurized Milk, Salt, Cultures, Enzymes), Modified Food Starch],
Breadcrumb [Wheat Flour, Vegetable Oil, Yeast, Sugar, Antioxidant (E300)], Egg, Wheat Flour,
Seasoning [Flavour Enhancer (E621, E635), Cornflour, Lactose, Hydrolyzed Vegetable Protein, Onion,
Palm Olein, Anti-Caking Agent (E551), Spices, Celery Seed].

Allergen Advice

Contains : Egg, Milk, Wheat

Country of Origin

Product of Singapore / Made in Singapore

Weight / Quantity

Per Piece (+/-1g) : 25g

Available Packing Size

Net Weight : 10 pcs/250g per pkt
20pkts/ctn

Packaging Type & Materials

Primary Packaging : Thermoforming Film
Top: PE/PA/PP/EVOH/EVA ; Bottom: PA/EVOH/PE
Secondary Packaging : Regular Slotted Corrugated Carton Box (RSC)

合利发私人有限公司 HA LI FA PTE LTD
No. 257 Pandan Loop Singapore 128434 Tel: (65) 6773 6209 Fax: (65) 6774 2010
Email: sales@halifa-bobo.com Website: www.halifa-bobo.com





Storage & Distribution / Shelf Life

Storage & Distribution : Frozen, -18°C and below
 Shelf Life : 12 months
 (cook before consumption)

Microbiological Specifications	Tolerance Limits
Aerobic Count (cfu/g)	< 1.0 x 10 ⁷
Escherichia coli (cfu/g)	< 20
Staphylococcus aureus (cfu/g)	< 20
Salmonella spp	Absent in 25gm
Listeria monocytogenes	Absent in 25gm

Food Safety Characteristic

All packed products passed through a calibrated metal detector
 Detection Limits: Ferrous <1.5mm, Non-Ferrous <2.5mm. Stainless Steel <3.0mm

Process Flowchart

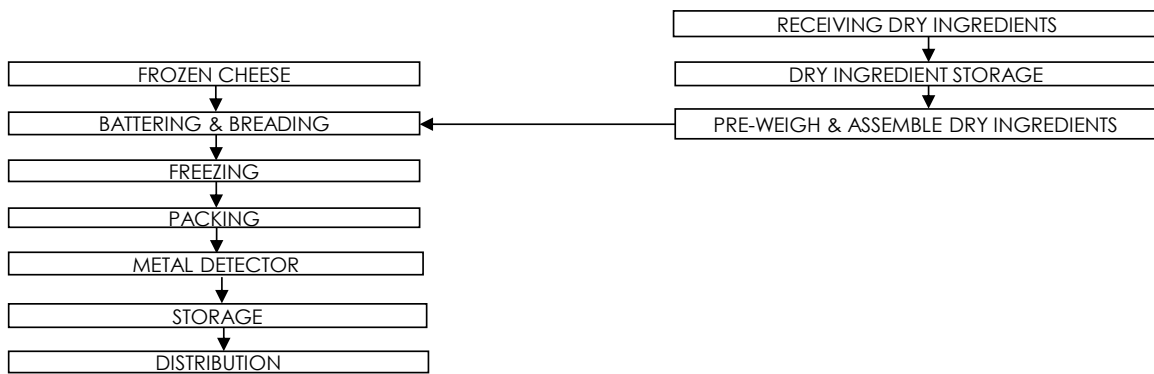

Target Consumer

General Public through Retailer and Super/Hypermarket

合利发私人有限公司 HA LI FA PTE LTD
 No. 257 Pandan Loop Singapore 128434 Tel: (65) 6773 6209 Fax: (65) 6774 2010
 Email: sales@halifa-bobo.com Website: www.halifa-bobo.com

